



Marine Fire Protection Systems



fire protection
TECHNOLOGIES



GASEOUS SUPPRESSION



WATER SUPPRESSION



FOAM SUPPRESSION



EXPLOSION PROTECTION



FIRE DETECTION



MILITARY & DEFENCE



SPECIAL APPLICATIONS



SUPPORT SERVICES



“Total flooding, clean agent fire extinguishing systems”

Marine Fire Protection Systems



“Total flooding, clean agent fire extinguishing systems”

U.S. Coast Guard studies show that approximately 90% of all marine fires start in the engine compartment. The same studies show that only one in ten marine fires is successfully extinguished with typical dry-chemical portable fire extinguishers due to the inherent difficulties of fighting a fire manually. In addition, dry-chemical fire extinguishers leave behind a powder that can damage the engine and sensitive electronic equipment.

Since pioneering the use of Halon systems in the early 1970's, Fireboy has designed safe and effective engine room fire protection with no water or powdery residue. All systems are heat activated to discharge the clean agent gas automatically at 175°F (79°C) with no operator intervention required. With a Fireboy system, the fire extinguishing agent is released much faster than any possible crew response, resulting in a faster fire-out time and less damage.

SHIPBOARD FIRES ARE MAJOR THREATS TO SAFETY

Of all the perils at sea, one of the most dangerous is fire. Difficult to deal with and potentially deadly, fire leaves the crew and passengers caught between two unforgiving elements. There's no local fire department to call. It's up to the crew to control the fire. Fire-fighting at sea and

on water is especially demanding. The complexity of design and component requirement of a traditional marine CO₂ system is there to achieve system safety, however, the results of an accidental discharge can be catastrophic.

SAFE FOR PEOPLE, EQUIPMENT AND ENVIRONMENT

Today's modern 'Clean Agents' are approved worldwide for use in 'Occupied' spaces, however even with these safe chemicals, similar design rules have to be maintained to comply with IMO SOLAS requirements. Just replacing the chemical agent will not only have a profound effect on safety, but will also increase the cost of the total system overall system.

CLEAN AGENTS REMOVE HEAT ENERGY, NOT OXYGEN

Every second counts when a fire occurs on-board. Clean Agent systems reach extinguishing levels in less than 10 seconds. Since even a few seconds can mean the difference between survival and a life destroying catastrophic fire, changing to the Fireboy FES system could give you a crucial margin of safety. That's why you need a fast, people-safe and effective fire suppressant: Clean Agent Waterless Fire

Protection from Fireboy-Xintex. The 'Fireboy' Electrically Released FES System provides the perfect choice for both new builds and refits and is currently the system of choice for many Commercial and Super yacht builders around the world. With the ability to eliminate a vast amount of industrial components the advantages in both weight and cost are evident.

FEATURE BENEFITS

- Safe for personnel
- Reduced component count
- Reduced piping
- Reduced weight
- Reduced nozzle count
- Electrically activated with manual back-up
- Ease of installation
- Cost effective replacement for CO₂
- System monitor integration
- Multiple discharge panel facility
- Lower stored pressure

APPROVALS

Approvals include Factory Mutual, U.S.C.G, Bureau Veritas, Llyods, RINA and others.

MA2 Series

Engine room up to 42.5 m³

MA2 SERIES MODEL

Ideal for boats with engine rooms up to 48 cubic meters in size, this series has an automatic discharge feature with an optional manual discharge, when used with a Fireboy Manual Discharge Cable, which is sold separately. Vertical or horizontal mounting is allowed.

MA2 Series:

- Automatic discharge with optional manual discharge when used with a Fireboy Manual Discharge Cable (sold separately)
- Engine rooms up to 42.5 cubic meters
- Vertical or horizontal mounting allowed
- HFC-227ea
- 'Manual Only' systems available for vessels under survey



READY TO INSTALL

Each Fireboy system comes complete with a powder coated cold rolled steel shelf bracket system and owner's manual.



GA1 & GA2 Series

Engine room from 45.3 m³ to 85 m³

The Fireboy GA Series is a patented, pre-engineered total-flooding fire extinguishing system designed to protect larger boats with engine rooms machinery spaces, and other enclosed spaces for Class B fires, from 45.3 cubic meters to 85 cubic meters.

A Clean Agent System featuring the use of HFC-227ea or 3M™ Novec™ 1230.

Features of the Novec™ 1230 agent are;

- Zero ODP
- Atmospheric life of 5 days
- GWP of less than 1
- 3M™ Blue Sky™ Warranty

APPROVALS

Includes; USCG, Llyods, Factory Mutual, Bureau Veritas and RINA.

GA PRE-ENGINEERED SERIES ADVANTAGES:

- Simplified installation versus engineered systems
- Installation can take place inside or outside the protected space
- Cylinder can be mounted close to the floor (2")
- Less costly than engineered systems
- System approvals available electronically
- Eliminates traditional on-site inspections
- All system components backed by the Fireboy-Xintex 3 year limited warranty against leaks and defects in materials and workmanship
- Patented safety lockout design prevents costly accidental discharge during installation or service



SYSTEM COMPONENTS



GA Link Features

- Quick disconnect for ease of installation
- Pressure gauge located at each sensor block
- Stainless steel braided hose



Pipe Kits Available Including:

- Pipe mounting brackets
- Nozzles
- Pipe

GA1 & GA2 APPROVED INSTALLATIONS:

GA1 Series extinguisher located inside the protected space:

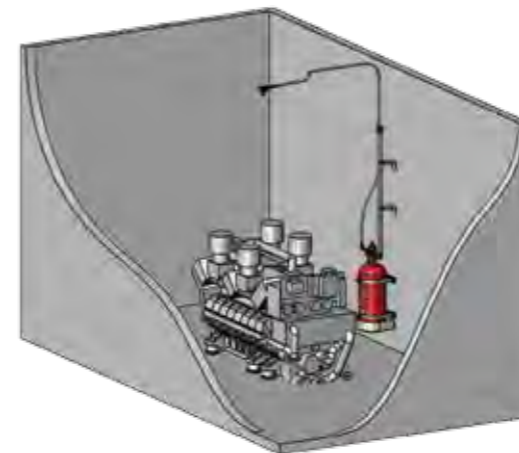

GA2 Series extinguisher installation with cylinders located inside the protected space

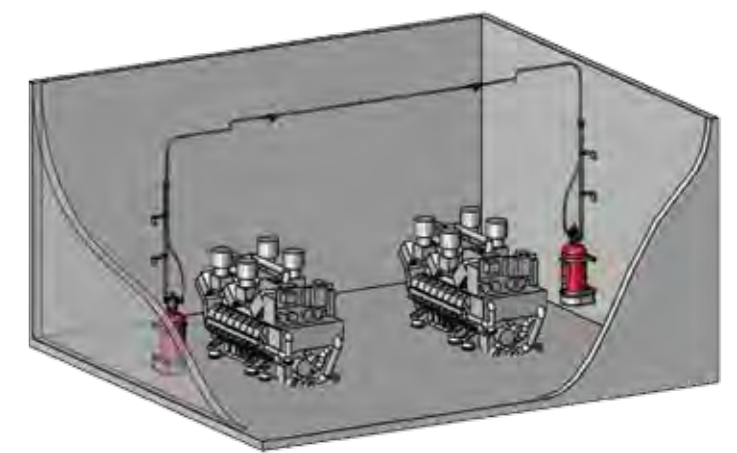

Approvals & Certifications

All Fireboy models meet AMSA approval requirements and are approved by Factory Mutual, U.S.C.G., and Bureau Veritas. Additionally, all systems containing HFC-227ea meet EN ISO 9094-1 and EN ISO 9094-2 Standards by Bureau Veritas, RINA, and Factory Mutual and are CE certified.

Fire Detection Systems

Monitor Engine Room & Accommodation Areas

The Fireboy-Xintex Fire Detection System provides an intelligent networked solution for the monitoring of 1, 2, 4, or 8 zones. Easy installation, does not require extensive set up or programming. The system consists of a monitor panel and up to 14 smoke or heat detectors per zone for a 12VDC system, or 8 detectors on a 24 VDC system, and/or rate of rise heat detectors connected to each zone (sold separately.)

MA & GA Extinguisher Accessories



HIGH-TEMPERATURE MANUAL DISCHARGE CABLES

Fireboy High-Temperature Manual Discharge Cables allow for the manual discharge of an MA2 or GA Series system when smoke or flames are detected and meet the U.S. Coast Guard flame-test guidelines. Determine the length of cable needed by measuring from the extinguisher head to the desired location where the red T-handle can be easily pulled. Use the shortest allowable cable when possible. Maximum allowed bending of the cable (in degrees) should not exceed 360° and should be taken into consideration when selecting the cable length and are required for all GA Series installations. Sold separately.



90107 FIRE SYSTEM STATUS INDICATOR PANEL

2" panel with LED light that provides constant monitoring of the system to comply with U.S.C.G. requirements for system approval. Included with CG2, MA2, & GA systems. Adhesive back for easy mounting.



DISCHARGE ALARM

With an integrated alarm horn for a single instrument installation. Includes "Test" button with waterproof boot and a lamp that illuminates when system is discharged. Model DA-1001-011 (round), DA-1001-021 (square, shown.)



ENGINE SHUTDOWN CONTROLS

Automatically shuts down engines, generators, blowers and dampers upon system discharge; 3, 5, or 8 circuit shutdowns available, 12VDC or 24/32VDC.



CABLE ANGLE ADAPTER

CAA-0285-01
Used with Fireboy Manual Discharge Cables when space limitations or owner preference call for an angled pull-out. Stainless steel.



DUAL RELEASE ADAPTER

Allows manual discharge of an MA2 or GA from 2 separate locations. Requires 2 Manual Discharge Cables. DRA-1001-01 includes 6' of cable, DRA-1001-02 includes 20' of cable, which should be taken into consideration when measuring for dual installations.

Monitor Display



FR-1000 (1 ZONE)

- No extensive programming
- Networked monitoring of 1 or 2 zones
- Stylish Water Resistant Display
- 2 5/8" Panel
- Visual indication from one location
- 85dB audible indication of fire or fault
- Installation diameter is 2 1/18"



FR-2000 (2 ZONE)

- Up to 14 smoke or heat detectors per zone (12vdc)
- Up to 8 smoke or heat detectors per zone (24vdc)
- Detectors sold separately
- Bases sold separately
- FR-100 input module NOT compatible



FR-4000 (4 ZONE)

- Programmable Networked Solution
- Communicates via 2 wire cable up to 3200 feet (not included)
- Networked monitoring of 4 to 8 zones
- Stylish Water Resistant Display
- Isolate any zone by name (Engine Room, Galley, etc.)
- Visual indication from one location
- 85 dB audible indication of fire or fault



FR-8000 (8 ZONE)

- Combination of 14 smoke or heat detectors per zone (12vdc)
- Combination of 8 smoke or heat detectors per zone (24vdc)
- Detectors sold separately
- Bases sold separately
- FR-100 input module included



FR-100 INPUT MODULE

- Compatible w/FR4000, FR8000 Only
- Interface between sensors & display
- Up to 8 separate zones
- 2 Output Relays
- 10A resistive @ 24vdc
- Relay 1 & 2 open on Fire Detection
- Relay 1 & 2 close when alarm is muted
- 6"W x 3.5"H x 1.5"D

Detectors & Bases



AP65-PESD-02

- Smoke Detector
- Photoelectric
- Hard wired
- 12/24vdc



AP65-HD170-02

- Heat Detector
- 170 degrees F
- Hard wired
- 12/24vdc



AP65-TB-01*

- Standard 4" Base
- Detector locking
- One way fit

*Optional sounder base AP65-SB-01

Gas Detection

Carbon Monoxide • Gasoline • Marine Propane

Carbon monoxide (CO) is produced wherever fossil fuel combustion occurs, including the operation of gasoline engines and heating and cooking appliances. It is invisible, odorless, tasteless, and deadly. Faulty venting or even a wind shift can create a dangerous situation, particularly in confined areas like boat cabins and sleeping quarters.

Carbon monoxide enters the bloodstream through the lungs, blocking the oxygen your body needs. Prolonged exposure to low concentrations or short exposure to high concentrations can be fatal. Typical symptoms of CO exposure can be mistaken for the flu, seasickness, or intoxication, making accurate on board CO detection a necessity.

PROTECT WHAT'S IMPORTANT

Installing and maintaining marine-grade CO detectors inside your boat can help protect you and your crew by helping to minimize the exposure to dangerous levels of carbon monoxide gas. Using the principle of "Time Weighted Averaging," Fireboy-Xintex CO detectors monitor CO concentration, temperature, and time to calculate levels of Carboxyhemoglobin (COHb). COHb is the degree to which the oxygen carrying capacity of the blood is impeded by the union of carbon monoxide to the hemoglobin and is expressed as a percentage. In layman's terms, our bodies prefer absorbing CO to oxygen and COHb is the ratio of absorbed carbon monoxide to oxygen in the bloodstream. Fireboy-Xintex CO detectors calculate this COHb as a function of time and determine the appropriate alarm time.

CARBON MONOXIDE CAN ACCUMULATE IN MANY WAYS

- Inadequately ventilated enclosures
- Blocked exhaust outlets
- Another vessel's exhaust
- The "station wagon effect" or back drafting
- At idle or slow speeds

EXPOSURE LEVEL & SYMPTOMS

- 200 PPM:** Slight headache within 2 to 3 hrs.
- 400 PPM:** Frontal headache within 1-2 hrs.
- 800 PPM:** Dizziness, nausea and convulsions within 45 min. Insensible within 2 hrs.
- 1600 PPM:** Headache, dizziness, nausea within 20 min. Death within 30 min.
- 3200 PPM:** Headache, dizziness and nausea in 5-10 min. Death within 30 min.
- 6400 PPM:** Headache and dizziness in 1-2 min.
- 12800 PPM:** Death in less than 3 min.

RECOMMENDED CARBON MONOXIDE DETECTOR INSTALLATION

 A carbon monoxide detector should be installed in each accommodation space. Small craft with an open design may require only one detector for adequate protection. If two or more sleeping areas or spaces are partitioned, then one detector should be installed in each of the spaces.

Ideally, installation of the detector should be at eye level for easy monitoring and service. However, Fireboy-Xintex CO detectors are approved for wall or ceiling mounting.

The detector should not be mounted within one foot of corners or other "dead air" spaces and should not be located within five feet of any cooking appliance.



CO Sentinel: CMD-4M-RLY

Model CMD-4M-RLY is a state-of-the-art carbon monoxide detector that utilizes a relay circuit allowing for the optional automatic shutdown of the generator upon detection of dangerous CO levels.



CO Sentinel: CMD-4M

The CMD-4M is a 12 VDC detector that is ideal when automatic generator shutdown and multiple location warning features are not desired.



SS-770 Smoke & Fire Alarm

The SS-770 is a 9V (battery included) general purpose smoke and fire alarm for use on boats and RVs.

The Silent Killer

In July 2013, four people were treated for carbon monoxide inhalation when their boat on the Tambo River near Paynesville filled with engine fumes. In April 2015 a boat was circling 500 metres offshore in Port Phillip Bay. When boarded by Police three people were found unconscious. Police believe a carbon monoxide leak was responsible. On 7th July 2015 three children were taken to hospital after a carbon monoxide leak on a boat at Lakes Entrance. They were all down below deck in the cabin where high levels of carbon monoxide were detected. These incidents occur time and time again, where the occupants of leisure boats are overcome and poisoned by the effects of Carbon Monoxide (CO).

Carbon Monoxide (CO) is produced in the exhaust gases of internal combustion engines, including gasoline powered generators, heating and cooking appliances. It is invisible, odourless and tasteless entering the bloodstream through the lungs, blocking the oxygen your body needs. Prolonged exposure to low concentrations or short exposure to high concentrations can be fatal. Typical symptoms of CO exposure can be mistaken for the flu, seasickness or intoxication, making accurate on board Carbon Monoxide detection a necessity.

The source of Carbon Monoxide may not come from your own boat but can be transferred from a neighbouring vessel within a marina environment. Where a wind shift can create a dangerous situation, particularly in confined areas such as boat cabins and sleeping quarters. Carbon Monoxide can accumulate in many ways. Inadequately ventilated enclosures, blocked exhaust outlets, another vessel's exhaust, and the "station wagon effect" or back drafting and at idle or slow speeds.

Installing and maintaining marine-grade CO detectors inside your boat

can help protect you, your family or crew by helping to minimise the exposure to dangerous levels of carbon monoxide gas. The detectors will alarm when 10% Carboxyhemoglobin (COHb) is reached in the space, COHb is the degree to which the oxygen carrying capacity of the blood is impeded by the union of carbon monoxide to the hemoglobin. This is well below dangerous levels and will alert occupants to vacate the space.

A carbon monoxide detector should be installed in each accommodation space. Small craft with an open design may require only one detector for adequate protection. If two or more sleeping areas or spaces are partitioned, then one detector should be installed in each of the spaces. Ideally, installation of the detector should be at eye level for easy monitoring and service.

Marine carbon monoxide detectors are manufactured to comply with UL Marine Standard 2034, Single and Multiple Station Carbon Monoxide Alarms. In that standard, Underwriter's Laboratories (UL) mandated a built in End of Life requirement for carbon monoxide detectors to ensure that these very important detectors maintain a high level of functional integrity to protect and warn about the presence of carbon monoxide.

It is important to remember that CO detectors degrade over time and must be checked and maintained. Once the detectors start degrading they emit an audible tone to alert the occupants that replacement is required. The built in 'End of Life' alert mechanisms usually occur between 5 and 10 years. Therefore, you should check the labels that identify the manufacture date of the unit, model and the 'End of Life' date.

REMEMBER: Carbon Monoxide (CO) is an odourless, silent, deadly killer that can impact on your boating experience with tragic consequences.

GAS

Gasoline Fume Detection...always on



M-1 Gasoline Fume Detector

An ideal single-channel gasoline fume detector. Features high-tech styling, compact 2" diameter size, circuitry "Test" and alarm horn "Mute" functions. The power on indicator lamp automatically increases in brightness in daylight and softens at night. The 90 dB alarm will sound when 18-20% LEL gasoline fumes are detected. Comes complete with one MS-2 sensor with 20' of lead cable. Available standard in black.

MB-1 Gasoline Fume Detector

All of the advanced features of the M-1, but with the added safety of a 10 amp relay to automatically start the bilge blower fan should fumes be detected. Installation requires only the addition of two wire leads from the control to the blower switch. To test, simply touch the "Test" pad on the control; the red alert lamp will glow, the alarm horn will sound and the blower motor will start. The system works with power requirements of up to ten amps at 12 VDC. Blowers up to 30 amps require an external relay, model MB30-RLY.



M-2A Gasoline Fume Detector

A microprocessor controlled, two-channel gasoline fume detector in a low profile, water resistant design. Features "Test" functions for each sensor. Illumination of the amber fault light indicates a sensor malfunction. The red LED will illuminate and the 75 dB alarm will sound when 18-20% LEL is reached. The "Alarm Silence" function deactivates the alarm horn. The system is calibrated to eliminate most nuisance alarms while allowing enough time to take action. Includes one MS-2 sensor and 20' of lead cable. A second sensor is optional and sold separately. Display size is 4.75" x 3.75" x 7/8".

MB-2 Gasoline Fume Detector

Includes all of the features of the M-2A plus automatic bilge blower control for added safety. The red LED will illuminate, the 75 dB alarm will sound, and the bilge blower will activate automatically when a fume level of 18-20% LEL is reached. The bilge blower will remain on until the fume level is safely lowered. The illumination of the amber fault light indicates a sensor malfunction. The system also includes a "Test" button to confirm that each sensor is functioning properly. A 30 amp relay is included for installation. One MS-2 sensor and 20' of lead cable are included. A second sensor is optional and sold separately. Display size is 4.75" x 3.75" x 7/8".

gas & propane ACCESSORIES

MB30-RLY
Auxiliary Relay
Thirty amp, single-pole double-throw relay for extra heavy loads. For use with the MB-1, MB-2 and S-2A only.



CNV-12-1 Voltage Reducer
For use when installing 12 VDC devices where on-board power suppliers are 24 or 32 VDC. Provides 1.25 amp output at 12 VDC. May be used with any device requiring 12 VDC with 1.25 amps or less input.



RH-1 Remote Horn
This 95 dB horn enables alarming in a remote location. Ideal for locations with extreme ambient noise or for the hearing impaired. For use with M-2A and MB-2 only.

PROPANE

Marine Propane Detection... a complete system



S-2A Propane Fume Detector with Solenoid Valve Control

A microprocessor controlled two-channel propane fume detector with solenoid valve control. ON/OFF switch opens and closes the solenoid valve with the touch of a button. Green LED indicates when valve is open. Includes one MS-2 sensor; second sensor is optional. Test buttons for each channel confirm sensor functions. The system is calibrated to alarm at 18-20% LEL (Lower Explosive Limit). 75 dB audible alarm. SV-1 solenoid valve is included. 12 VDC operation. Display size 4.75" x 3.75" x 7/8".

S-1A Propane Fume Detector with Solenoid Valve Control

Single-channel propane fume detector with solenoid valve control. The 90 dB alarm sounds at 18-20% LEL and the red LED will illuminate. The "Valve ON/OFF" button opens and closes the solenoid valve. The middle green LED indicates when valve is open and the left green LED indicates normal operation mode when the power is on. Includes one MS-2 sensor and SV-1 solenoid valve. 12 VDC operation. Display size is 2" x 2" x 7/8".

C-1 Control

Solenoid valve control with easy-touch ON/OFF button. Red LED indicates when the solenoid valve is open. The solenoid valve is normally closed and must have power applied to open. Fail-safe feature includes automatic valve closure in a power failure situation. 12 VDC operation with connections at convenient terminal strip. Includes one SV-1 solenoid valve. Display size is 4.75" x 3.75" x 7/8".

S-1 Propane Fume Detector

Single-channel propane fume detector with a compact 2" diameter display. Solenoid valve control NOT available. Includes "Test" and "Mute" functions. The 90 dB alarm sounds at 18-20% LEL and the red LED will illuminate. When illuminated, the green LED will indicate normal operating mode. Includes one MS-2 sensor and 20' of cable. 12 VDC operation.

Solenoid Valves

Operates on 12 VDC. Opens/closes flow of propane when powered. Automatically closes with low or no current for added safety.

SV-1 1/4" female NPT inlet, 1/4" male NPT outlet. Includes 3/8" Male Flare x 1/4" Female NPT brass fitting (PF-5446). Rated for 0-312 psi. Orifice size is 0.110". UL Listed.

SV-2 3/8" solenoid valve for use with C-1, S-1A and S-2A. Operates on 12 VDC. Opens the flow of propane when powered and automatically closes with low or no current for added safety. 3/8" female NPT inlet, 3/8" female NPT outlet. Rated for 0-350 psi.

PA-5429 LPG Leak Test Adapter

Adapts non-marine LPG regulators to meet ABYC Standards. Installs between LPG cylinder and regulator or pigtail hose. Assembled with 300 psi pressure gauge. Brass male POL x female POL receptacle.



About Fire Protection Technologies



"To provide our customers with the best possible service, the highest quality products and the right solution for their needs"

Fire Protection Technologies is the largest independent supplier of product, design and engineering services in Australia, New Zealand and Asia Pacific. In conjunction with our 'whole of life' approach to our product range, technical support, design and engineering solutions available throughout all stages of a project from development to delivery, we will continue to provide ongoing support for the life of the product.

Wholly Australian owned and operated we have a team dedicated to customer support, complete with 350+ years combined practical experience in delivery and engineering of special hazards projects.

Being the sole distributor in this region for some of the world's largest and technically advanced product manufacturers, together with our technical capabilities enables us to provide the highest quality products including technical and product support.

Our philosophy "EVERY SOLUTION FOR YOUR SPECIAL HAZARD PROBLEMS" drives us to continue searching the world for the highest quality products to combine with our existing product range in order to provide the best possible solution for your special hazard problems to protect people, property and business continuity from the hazards of fire and explosion.

A brief summary of our range of products complete with, design, engineering, technical support and training services, include:

- Gaseous Suppression Products
- Water Suppression Products
- Foam Suppression Products
- Explosion Protection Products
- Fire Detection Products
- Military & Defence Solutions
- Special Application Products
- Support Services

DESIGN & ENGINEERING

"All systems are specifically engineered to suit the particular situation"

Our highly trained engineering team are capable of providing a full range of services extending from simple product advice right through to detailed system design and engineering, including hydraulic analysis and risk assessment. We are capable of providing a fire or explosion protection solution for practically any fire or explosion hazard.

In addition, our experienced project management team provides a turnkey solution on those projects that require installation, project management, commissioning and ongoing maintenance services.

Our services include:

- Design Services
- Design Drawings
- Project Documentation
- Project Management
- Cost Analysis
- System Hydraulics

TECHNICAL SUPPORT

"Our engineering staff are always available to assist with any query"

At Fire Protection Technologies we understand the difficulties that often arise during system commissioning and routine maintenance. That's why our engineering staff are always available to assist with any query. We are able to help throughout Australasia with specific product queries, on-site commissioning assistance, system design analysis and design verification.

Our services include:

- Design Verification
- Commissioning
- Hazard / Risk Analysis
- Product After Sales Service
- Field Support

SERVICES & TESTING

"Our trained personnel can service and test to confirm compliance and provide peace of mind"

Component testing and verification are vital in order to confirm a fire protection system's ability to operate and perform as originally designed. We are able to test and verify everything from manifolds and piping systems, extinguishing agent storage containers to foam concentrate compliance and explosibility characteristics. That's why our comprehensive testing services are highly sought after within the Fire Protection Industry. In addition, we provide regular inspection services for all types of Special Hazard Fire Protection systems.

Other services include:

- Hydrostatic Pressure Testing
- System Recharging / Reinstatement
- Enclosure Integrity Testing
- Integrity Testing Equipment Calibration
- Foam Concentrate Testing
- Explosibility Testing
- Maintenance Services
- Training
- De-Commissioning
- Pipe & Fittings



PRODUCTS:

Gaseous Suppression



Inert Gas (IG-01, IG-55, IG-100, IG-541)
Novec 1230™ Fluid (FK-5-1-12)
FM-200® (HFC-227ea.)
Carbon Dioxide (CO₂)
Hybrid Systems (N₂ / Water)
Pressure Relief Vents
Enclosure Integrity Testing Equipment
Pipe & Fittings

Water Suppression



Water Mist - High Pressure
Water Mist - Intermediate Pressure
Water Mist - Low Pressure
Hybrid Systems (Water / N₂)
Monitors & Delivery Systems
High Speed Deluge

Foam Suppression



Foam Concentrates
Foam Proportioning
Foam Delivery Systems
Compressed Air Foam
Foam Concentrate Testing

Explosion Protection



Explosion Suppression
Explosion Isolation
Explosion Vents & Pressure Relief
Spark Suppression
Explosibility Testing

Fire Detection



Linear Heat Detection - Digital
Linear Heat Detection - Fibre Optic
Linear Heat Detection - Micro Chip
Flame Detection
Video Imaging Detection
Spark Detection
Control & Indicating Equipment
Thermal Imaging Detection
Aspirating Smoke Detection

Military & Defence



Military Vehicles
Naval Vessels

Special Applications



Micro Environment
Oxygen Reduction
Kitchen Protection Systems
Dry Chemical
Vehicle Systems
Marine & Offshore
Vapour Mitigation
Li-Ion Fire Systems

Support Services



Design / Engineering
Technical Support
Services & Testing

Australia

Head Office

Unit 1, 251 Ferntree Gully Road
Mt Waverley VIC 3149
Australia

Brisbane Office

Unit 7, 93 Rivergate Place
Murarrie QLD 4172
Australia

Perth Office

18 – 20 Ledgar Road
Balcatta WA 6021
Australia

Sydney Office

Unit 5, 11 Reliance drive Tuggerah
NSW 2259
Australia

1300 742 296

www.fire-protection.com.au
enquiries@fire-protection.com.au

New Zealand

Auckland Office

Unit 2, 13 Airborne Road
Albany North Shore 0632
New Zealand

0011 64 9415 5488

www.fire-protection.net.nz



‘Every solution for your special hazard problems’