



# af-x fireblocker



**AF-X Maintenance Keyswitch**  
**Article:** 25-10-621-00-00

## TECHNICAL INFORMATION

<b>main power</b>	24V
<b>visual LED</b>	on = system in maintenance & AF-X Fireblockers are disconnected off = system is active
<b>dimensions (h x w x d)</b>	105 x 65 x 55 mm

## AF-X Maintenance Switch



Maintenance Key switch

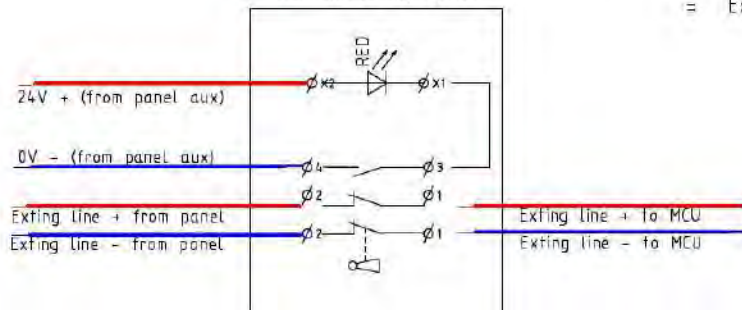

### Wiring of the maintenance key switch

- 24V aux power to LED
- Extinguishing line from panel to key switch contacts
- extinguishing line form key-switch to MCU

### When in normal state:

- = Extinguishing line is closed and led is dark
- = Key can be taken out

### When in maintenance mode

- = Key is locked (can't take out the key)
- = LED is bright red
- = Extinguishing line is open (fault on panel)

## PRODUCTS:

### *Gaseous Suppression*



Inert Gas (IG-01, IG-55, IG-100, IG-541)  
Novec 1230™ Fluid (FK-5-1-12)  
FM-200® (HFC-227ea.)  
Carbon Dioxide (CO<sub>2</sub>)  
Hybrid Systems (N<sub>2</sub> / Water)  
Pressure Relief Vents  
Enclosure Integrity Testing Equipment  
Pipe & Fittings

### *Water Suppression*



Water Mist - High Pressure  
Water Mist - Intermediate Pressure  
Water Mist - Low Pressure  
Hybrid Systems (Water / N<sub>2</sub>)  
Monitors & Delivery Systems  
High Speed Deluge

### *Foam Suppression*



Foam Concentrates  
Foam Proportioning  
Foam Delivery Systems  
Compressed Air Foam  
Foam Concentrate Testing

### *Explosion Protection*



Explosion Suppression  
Explosion Isolation  
Explosion Vents & Pressure Relief  
Spark Suppression  
Explosibility Testing

### *Fire Detection*



Linear Heat Detection - Digital  
Linear Heat Detection - Fibre Optic  
Linear Heat Detection - Micro Chip  
Flame Detection  
Video Imaging Detection  
Spark Detection  
Control & Indicating Equipment  
Thermal Imaging Detection  
Aspirating Smoke Detection

### *Military & Defence*



Military Vehicles  
Naval Vessels

### *Special Applications*



Micro Environment  
Oxygen Reduction  
Kitchen Protection Systems  
Dry Chemical  
Vehicle Systems  
Marine & Offshore  
Vapour Mitigation  
Li-Ion Fire Systems

### *Support Services*



Design / Engineering  
Technical Support  
Services & Testing

## Australia

### Head Office

Unit 1, 251 Ferntree Gully Road  
Mt Waverley VIC 3149  
Australia

### Brisbane Office

Unit 7, 93 Rivergate Place  
Murarrie QLD 4172  
Australia

### Perth Office

18 – 20 Ledgar Road  
Balcatta WA 6021  
Australia

### Sydney Office

Unit 5, 11 Reliance drive Tuggerah  
NSW 2259  
Australia

**1300 742 296**

[www.fire-protection.com.au](http://www.fire-protection.com.au)  
[enquiries@fire-protection.com.au](mailto:enquiries@fire-protection.com.au)

## New Zealand

### Auckland Office

Unit 2, 13 Airborne Road  
Albany North Shore 0632  
New Zealand

**0011 64 9415 5488**

[www.fire-protection.net.nz](http://www.fire-protection.net.nz)



**'Every solution for your special hazard problems'**