



af-x fireblocker



Tyco CO Thermal Multi detector
article: 23-50-468-00-00

TECHNICAL INFORMATION

type	601CH Carbon Monoxide Fire Detector
approvals	EN54: Part 5
operating voltage	10,5V - 33 V dc
quiescent current (typ)	87 μ A
max. current alarm	75 mA
Holding Voltage	5V
Holding current	3mA
operating temperature range	-10 °C to + 55 °C
max. humidity	90%RH - Non Condensing (at 40 °C)
ingress protection rating	IP42
weight	90 g (ex. base)
diameter / height	109 / 43 mm

description

601CH have fast response in fire detection, are tolerant in positioning and can be mounted in locations where there are like to be obstacles to free smoke plume movement. These detectors are particularly well suited to areas prone to false alarm and detection of Lithium fires. The integrated rate of rise detector acts as a normal heat detector, additionally enhancing the sensitivity of the carbon monoxide detector if a rapid change of temperature is detected by the detector thermistor.

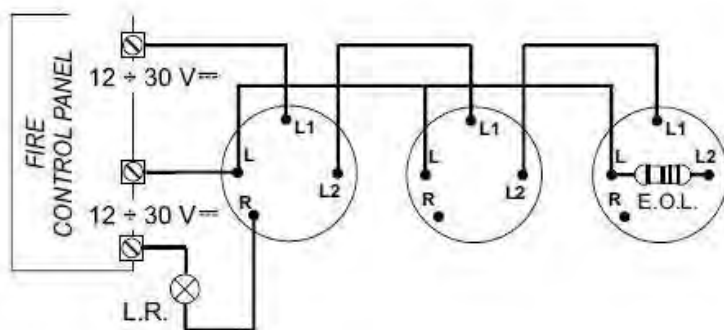

PRODUCTS:

Gaseous Suppression



Inert Gas (IG-01, IG-55, IG-100, IG-541)
Novec 1230™ Fluid (FK-5-1-12)
FM-200® (HFC-227ea.)
Carbon Dioxide (CO₂)
Hybrid Systems (N₂ / Water)
Pressure Relief Vents
Enclosure Integrity Testing Equipment
Pipe & Fittings

Water Suppression



Water Mist - High Pressure
Water Mist - Intermediate Pressure
Water Mist - Low Pressure
Hybrid Systems (Water / N₂)
Monitors & Delivery Systems
High Speed Deluge

Foam Suppression



Foam Concentrates
Foam Proportioning
Foam Delivery Systems
Compressed Air Foam
Foam Concentrate Testing

Explosion Protection



Explosion Suppression
Explosion Isolation
Explosion Vents & Pressure Relief
Spark Suppression
Explosibility Testing

Fire Detection



Linear Heat Detection - Digital
Linear Heat Detection - Fibre Optic
Linear Heat Detection - Micro Chip
Flame Detection
Video Imaging Detection
Spark Detection
Control & Indicating Equipment
Thermal Imaging Detection
Aspirating Smoke Detection

Military & Defence



Military Vehicles
Naval Vessels

Special Applications



Micro Environment
Oxygen Reduction
Kitchen Protection Systems
Dry Chemical
Vehicle Systems
Marine & Offshore
Vapour Mitigation
Li-Ion Fire Systems

Support Services



Design / Engineering
Technical Support
Services & Testing

Australia

Head Office

Unit 1, 251 Ferntree Gully Road
Mt Waverley VIC 3149
Australia

Brisbane Office

Unit 7, 93 Rivergate Place
Murarrie QLD 4172
Australia

Perth Office

18 – 20 Ledgar Road
Balcatta WA 6021
Australia

Sydney Office

Unit 5, 11 Reliance drive Tuggerah
NSW 2259
Australia

1300 742 296

www.fire-protection.com.au
enquiries@fire-protection.com.au

New Zealand

Auckland Office

Unit 2, 13 Airborne Road
Albany North Shore 0632
New Zealand

0011 64 9415 5488

www.fire-protection.net.nz



'Every solution for your special hazard problems'