



af-x fireblocker



AF-X MCU (Monitoring & Control Unit)
Article: 21-10-361-00-01

TECHNICAL INFORMATION

dimensions (h x w x d)	95 x 120 x 45 mm
material	plastic (halogen free)
protection rate	IP65
cable capacity	0.5mm ² to 2.5mm ²
input delay time	500 milliseconds +/- 100 milliseconds
output duration	1 second +/- 400 milliseconds -
end of line resistor	- 10K with AF-X TEC & S-TEC - 6K8 with RP1r-SUPRA (Notifier)
end of line diode	- 1N4004 with Kentec XT

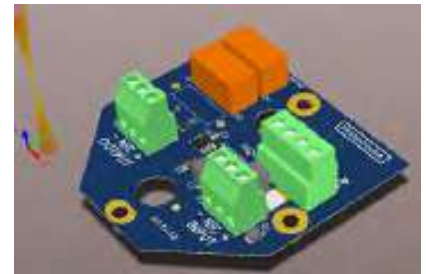

AF-X Monitoring & Control Unit

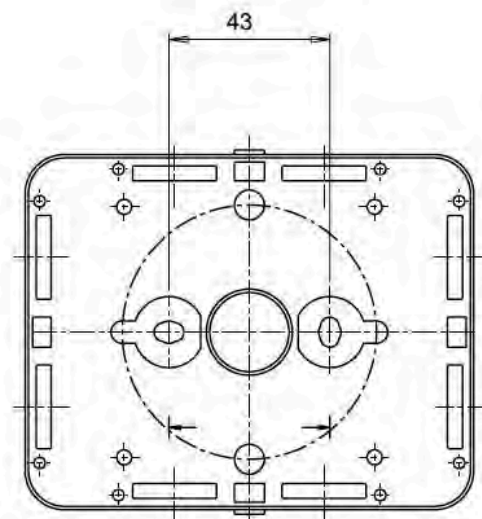
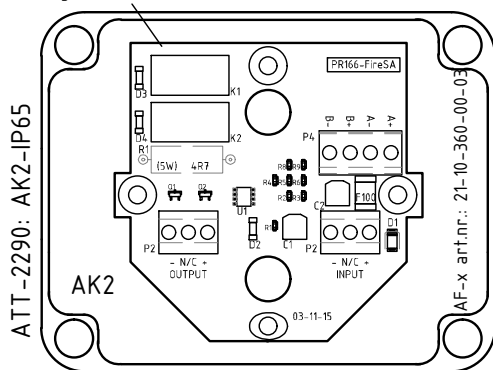

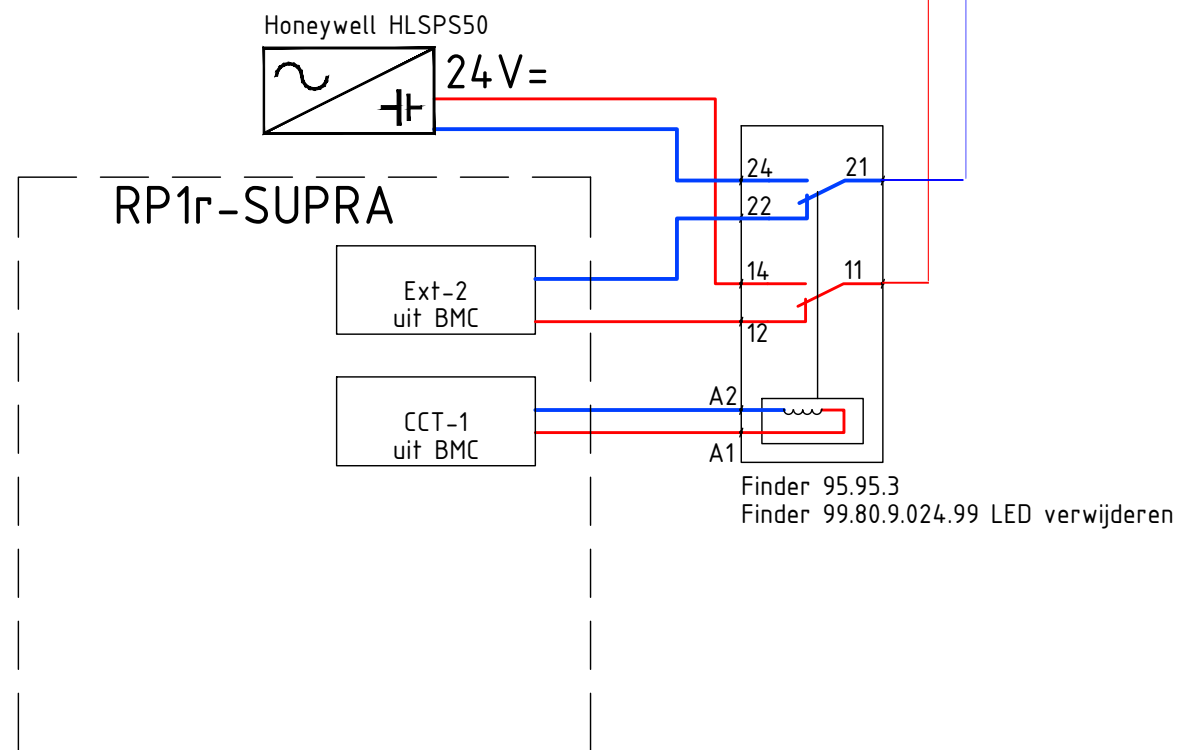
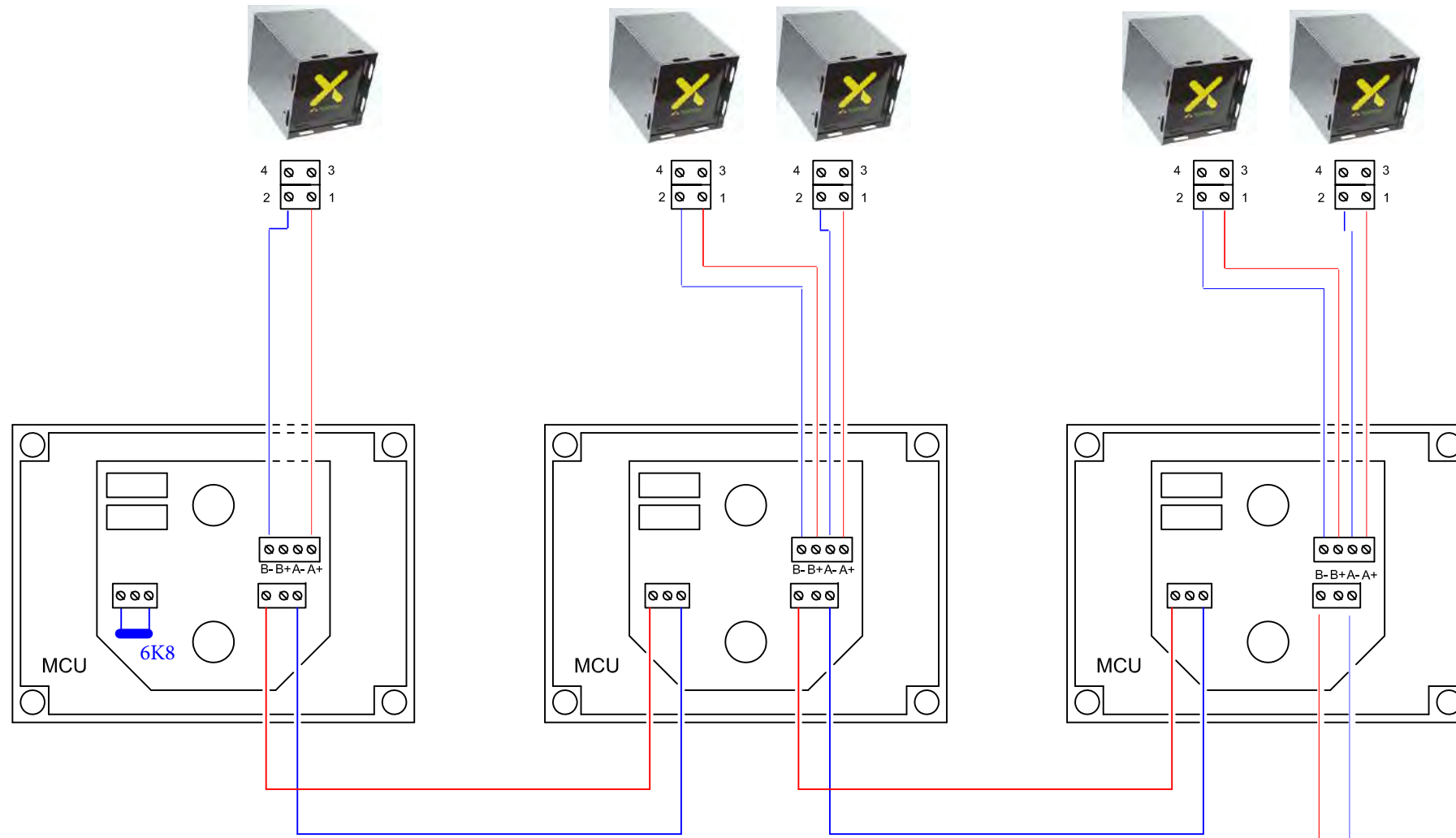

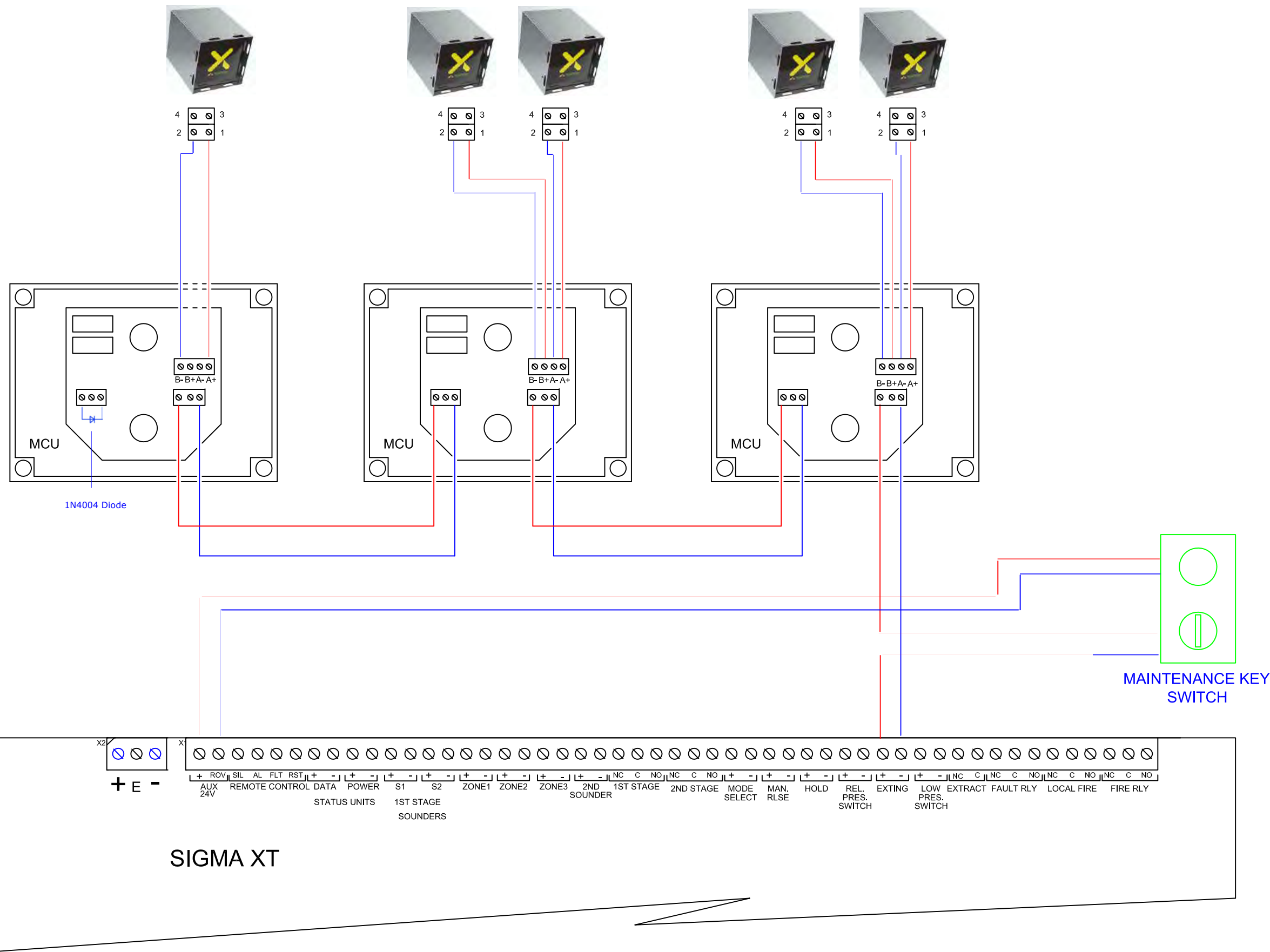

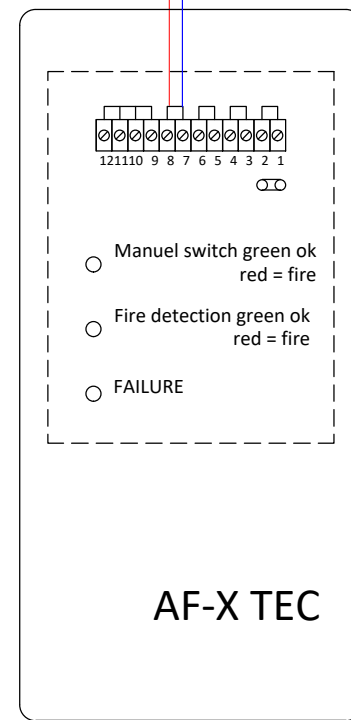
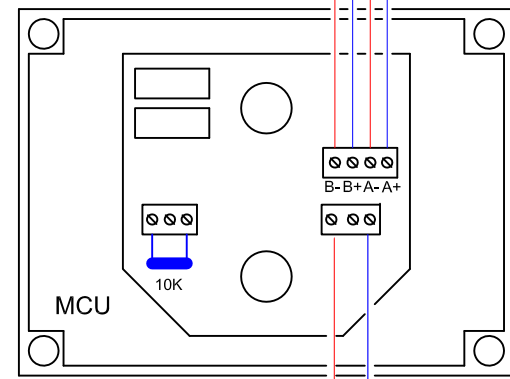
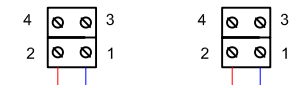

7 = + AFX
8 = - AFX

PRODUCTS:

Gaseous Suppression



Inert Gas (IG-01, IG-55, IG-100, IG-541)
Novec 1230™ Fluid (FK-5-1-12)
FM-200® (HFC-227ea.)
Carbon Dioxide (CO₂)
Hybrid Systems (N₂/ Water)
Pressure Relief Vents
Enclosure Integrity Testing Equipment
Pipe & Fittings

Water Suppression



Water Mist - High Pressure
Water Mist - Intermediate Pressure
Water Mist - Low Pressure
Hybrid Systems (Water / N₂)
Monitors & Delivery Systems
High Speed Deluge

Foam Suppression



Foam Concentrates
Foam Proportioning
Foam Delivery Systems
Compressed Air Foam
Foam Concentrate Testing

Explosion Protection



Explosion Suppression
Explosion Isolation
Explosion Vents & Pressure Relief
Spark Suppression
Explosibility Testing

Fire Detection



Linear Heat Detection - Digital
Linear Heat Detection - Fibre Optic
Linear Heat Detection - Micro Chip
Flame Detection
Video Imaging Detection
Spark Detection
Control & Indicating Equipment
Thermal Imaging Detection
Aspirating Smoke Detection

Military & Defence



Military Vehicles
Naval Vessels

Special Applications



Micro Environment
Oxygen Reduction
Kitchen Protection Systems
Dry Chemical
Vehicle Systems
Marine & Offshore
Vapour Mitigation
Li-Ion Fire Systems

Support Services



Design / Engineering
Technical Support
Services & Testing

Australia

Head Office

Unit 1, 251 Ferntree Gully Road
Mt Waverley VIC 3149
Australia

Brisbane Office

Unit 7, 93 Rivergate Place
Murarrie QLD 4172
Australia

Perth Office

18 – 20 Ledgar Road
Balcatta WA 6021
Australia

Sydney Office

Unit 5, 11 Reliance drive Tuggerah
NSW 2259
Australia

1300 742 296

www.fire-protection.com.au
enquiries@fire-protection.com.au

New Zealand

Auckland Office

Unit 2, 13 Airborne Road
Albany North Shore 0632
New Zealand

0011 64 9415 5488

www.fire-protection.net.nz



'Every solution for your special hazard problems'