

Features

For inside air use
Excellent foaming properties
Recommended foam Fomtec LS EXP
DIN or ANSI flange option

Description

The Bele high-expansion foam generator is designed for total flooding systems or local application of high expansion foam. The massive volume of expanded foam will keep the water application to a minimum and extinguish through a combination of vapour suppression, cooling, oxygen reduction and wetting capability.

Application

The Bele high expansion foam generators can be used for applications such as:

- Aircraft Hangars
- Ship Holds and engine rooms
- Power stations and transformers
- Gas turbine generators
- Flammable liquid storage
- LNG vapour suppression



Recommended foam concentrate

- Fomtec LS EXP 2% high expansion foam concentrate

Operation

The Bele high expansion foam generators is water driven and does not require any other power source. It can be attached to any foam proportioning system such as inductor, bladder tank or foam pump.

Options

- DIN or ANSI flanged inlet connection

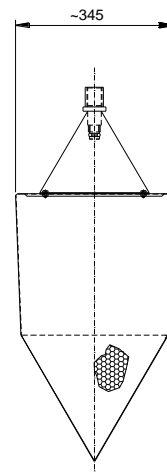
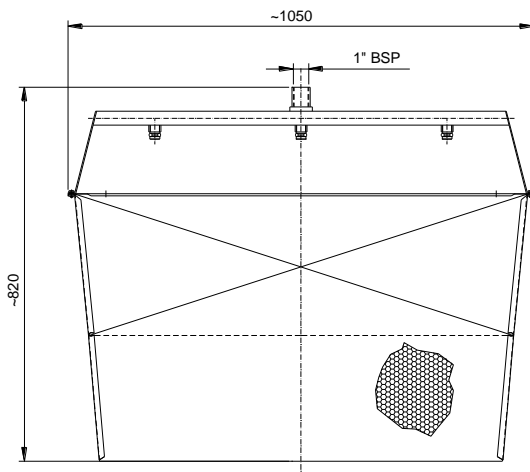

Tested with inside air
Dimensions are in mm

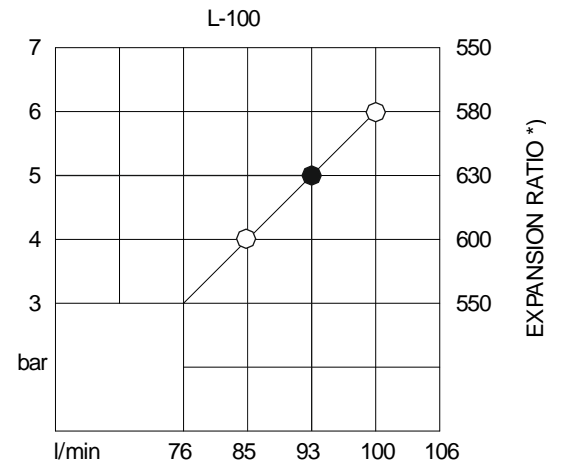

*) Depending on the foam concentrate used

Technical data

Model	Working pressure	Flow rate L/min – 5 bar	Expansion ratio 5 bar (1)	Weight Kg
BELE L-100	3 ÷ 8	91	450-600:1	10

(1): Test executed at 20°C, windless using fresh air (recommended). The expansion ratio is depending on foam concentrate type. The performance does not change significantly if combining inside smoke polluted air with Fomtec LS EXP high expansion foam concentrate.