

MODULE SELECTION GUIDE

Guide on selecting the type and number of components for Fike's explosion protection control systems

DESCRIPTION

Explosion Protection Controller (EPC)

The cornerstone of the system is the Explosion Protection Controller (EPC). The EPC is an addressable panel that has the ability to retain event history for enhanced system diagnostics.

The EPC should be installed as close as practically possible to the protected environment, thereby minimizing field wiring.

The EPC has 2 analog 4-20 mA detection inputs to connect transducer type detectors (1 to each input) which can be programmed for pressure warning, static threshold, and rate of rise (dynamic) detection.

It has a contact closure detection circuit to support thermal, infrared, or other switch-closure type detection devices.

A supervisory input circuit is provided to monitor suppression container pressure switches or other similar system status safeguards.

The EPC has a remote disable input contact to allow for disabling the EPC during product loading, cleaning, or maintenance from a customer PLC or other remote device.

The EPC can actuate up to six (6) GCA actuators. The table below details the number of GCAs used per component, see also selecting the number of EPCs.

Component	Number of GCAs per component
Suppression Container	1
Isolation Valve 2-10"	1
Isolation Valve 12-18"	2
Isolation Valve 20"	3

Power Supply Unit (PSU)

The EPC is powered by the Power Supply Unit (PSU). The PSU has six separate 24 VDC, 1 amp power output circuits capable of powering up to four EPCs, an Annunciator Module (AM), and four Relay Card Modules (RC8).

The PSU may be eliminated if battery backed, uninterrupted 24 VDC, 2A power per module can be provided by others. FM requires UL approved uninterruptible power supply.

The Annunciator Module (AM)

The Annunciator Module (AM) provides a central communication point for diagnostics and programming. This module will typically be installed remotely, in the control room. It controls the operation of up to 4 EPC, 1 PSU, 4 RC8. The AM stores up to 40 of the most recent events with real time clock information.

Relay Card Module (RC8)

The Relay Card Module (RC8) provides the user with eight relays for equipment shutdowns and remote notification of system trouble and alarm conditions. DIP switches are provided for configuring the relays for standard relay operations. Expanded relay programming can be done using the EPWorks Software.

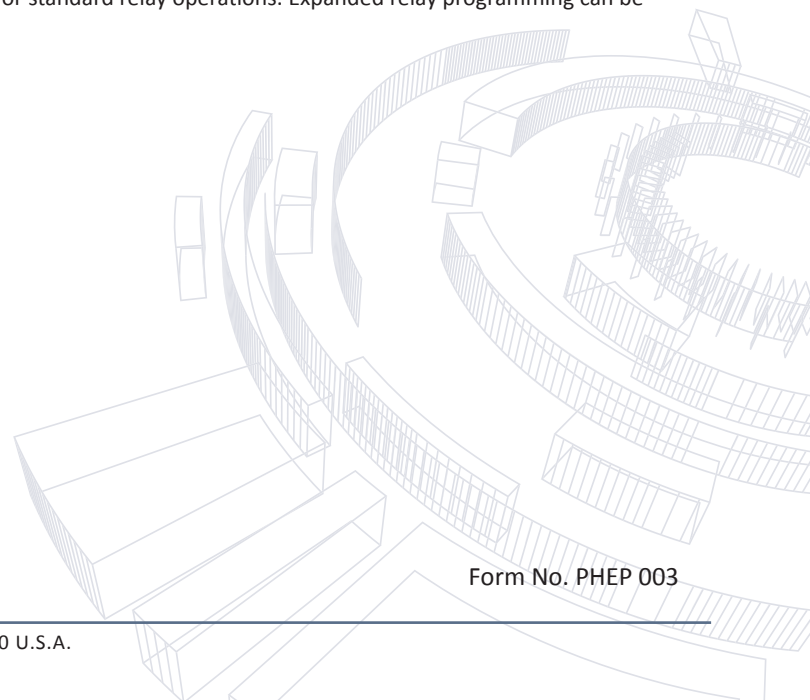

Form No. PHEP 003

Bus Network

Fike introduces the use of bus network technology to the explosion protection industry. The Fike explosion protection control system uses bus network technology to exchange information between its components, and to 'connect' protection controllers to 'enlarge' the protected area if required. The control system has three separate communication circuits, or buses. Two of the three bus circuits are utilized on the EPC; the status bus and the fire bus. The status bus ties all the various modules together to form a network for reporting of system status to an Annunciator Module. The high speed fire bus commands up to 16 modules within 2 milliseconds. The third bus, is the remote bus.

In the figure adjacent, a full setup is shown (with the maximum number of each type of component) which composes a 'Single loop.'

See the 'Bus Network Technology' guide for additional information on the bus network.

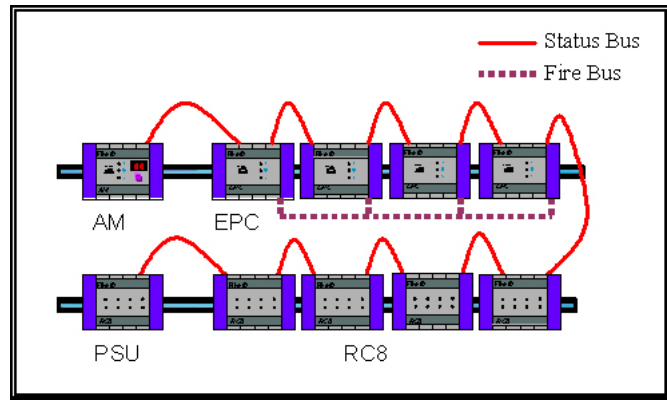

SELECTING THE NUMBER OF EPCS

The number of EPCs required for an application is the result of the following selection process:

- A maximum of 6 actuators in series can be activated by one EPC. If more than 6 actuators should be activated at the time of detection, EPCs shall be connected through the 'fire bus' to compose a larger zone or protected area.
- The EPC is a 'single zone' type controller. This means that all actuators (detonators or gas cartridge actuators) connected to that EPC will be activated simultaneously when the detection conditions (static, dynamic or combination) are met. There is no possibility to 'selectively' activate actuators connected to an EPC. If one or more actuators should not be activated with other actuators, multiple EPCs shall be used, with fire bus not used.
- A maximum of 2 transducer type detectors can be connected to one EPC. If the application requires more than 2 transducer type detectors on the protected area (for instance large or tall vessels), multiple EPCs can be used to facilitate this - connected via the fire bus.

SELECTING THE NUMBER OF PSUs

The PSU has six separate 24 VDC, 1 amp power output circuits capable of powering up to four EPCs, the AM, and four RC8s of the explosion protection control system.

SELECTING THE NUMBER OF AMs

Each Annunciator Module is capable of piloting up to four (4) EPC's, four (4) relay cards (RC8) and one PSU.

SELECTING THE NUMBER OF RC8s

The number of relay cards can be selected based on the relay information required by the customer. Up to four relay cards, with eight (8) relays per card, can be utilized with each PSU and AM. The relay functions can be selected by either the predefined DIP switch settings, or by using the EPWorks™ software.