

RELOAD PARTS FAV

After activation the Fike Fast Acting Valve (FAV) can be refurbished using the Fike reload parts as detailed below.

Refurbishing the valve must only be performed by a Fike service technician or trained site personnel, using original Fike parts only!

The following items are required for refurbishing the FAV

- Reload kit FAV
- Initiator in safety enclosure

The reload kit FAV consists of these parts (refer to sketch)

- ① Gate demper
- ② Teflon disc (2x)
- ③ Gasket cylinder
- ④ Gasket cylinder
- ⑤ Flange seal O-ring
- ⑥ Initiator boss O-ring
- ⑦ O-ring
- ⑧ Spanbus
- ⑨ Non return valve
- ⑩ Initiator boss

The initiator in safety enclosure

It can be either a valve actuator assembly (GCA) or a detonator (DETO) in safety enclosure which will be shipped in a separate wooden box according to ADR and IATA regulations for 1.4S products - unless not required by local or national authorities.

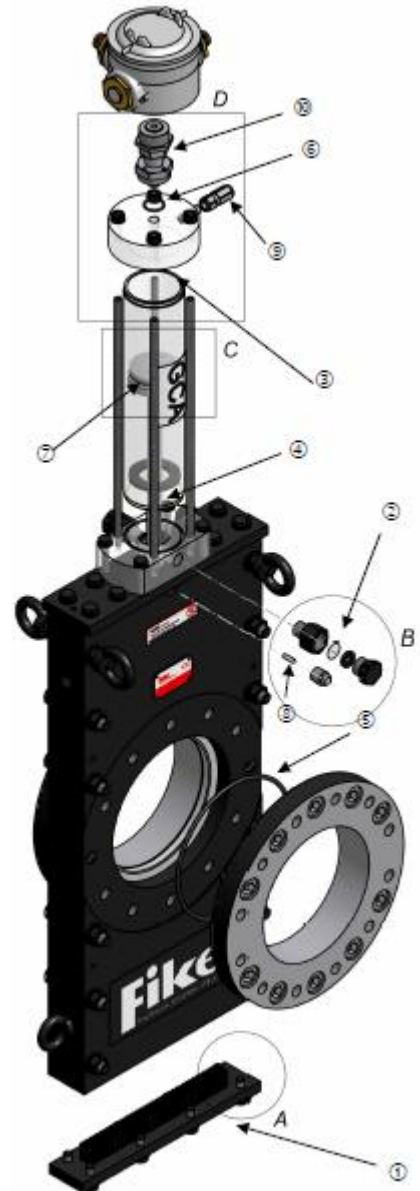



Notes

The flange seal O-rings (item 5) only have to be replaced if they are damaged (a reload kit can be ordered without flange seal O-rings if these are not required).

For valves > 10" (DN250) there will be two stripper bolts (item 11) included in the reload kit since the two bottom bolts will be deformed after activation.

For valves with valve actuator assembly and open/close module, there will be a non return valve (item 9) included in the reload kit since this will be damaged after activation.

The teflon discs (item 2) will only be included for a valve with no open/close module.

