

## ■ DATA SHEET PROPORTIONER FD6000 FOR STATIONARY EXTINGUISHING SYSTEMS.

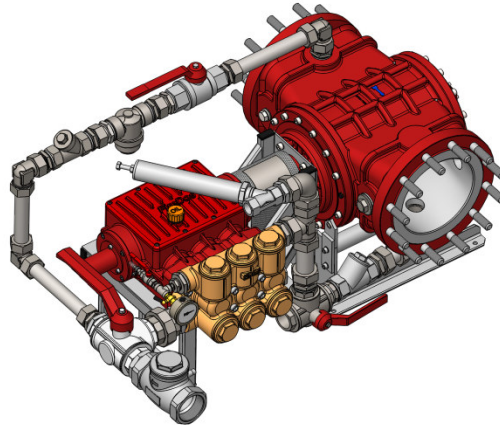

### ■ 1. TECHNICAL DATA.

Proportioning rate	0.5%	1%	3%	6%	3% + 3%
Approvals	-	FM 3039305 <sup>2</sup>	FM 3039305 <sup>1</sup>	-	-
	-	VdS G4080017 <sup>2</sup>		-	-
	DNV-GL TAF00000GK <sup>1</sup>				
Flow directions of water motor	Horizontal: "left → right" or "right → left" Vertical: "top → bottom" or "bottom → top"				
Min. water flow rate <sup>3</sup>	400 l/min	500 l/min	500 l/min	600 l/min	700 l/min
Min. water flow rate <sup>3</sup> with flow reduction	140 l/min	170 l/min	170 l/min	200 l/min	240 l/min
Max. water flow rate	6000 l/min				
Operating temperature	5 °C – 50 °C				
Max. operating pressure	16 bar				
Weight <sup>4</sup>					
Freshwater version	150 kg	150 kg	210 kg	420 kg	300 kg
Seawater version	262 kg	272 kg	317 kg	550 kg	364 kg
ATEX classification (optional) <sup>5</sup>	Ex CE II 2G IIC c T4 / II 2D IIIC c T<130°C				

1) Applies to pump generation I and II.

2) Applies to pump generation I.

3) Proportioning starts even at a lower water flow rate. The nominal proportioning rate is achieved when reaching the specified figure.

4) Weight indication is based upon a proportioner with a service crank. Further accessories installed at the proportioner will increase the specified weight. Weight indications do not consider extinguishing water or foam agent.

5) The proportioner does not have a service crank if it is an ATEX version. Divergent materials are possible.



## ■ 2. PRESSURE LOSS.

The actual pressure loss may slightly vary, depending on the operating conditions.

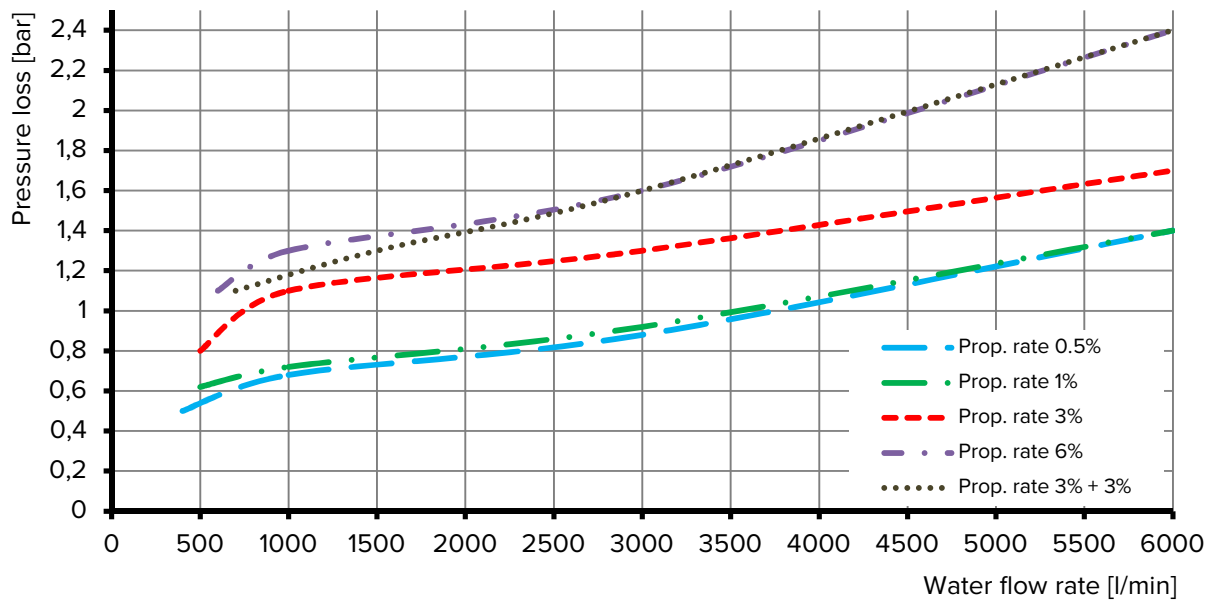

## ■ 3. MATERIALS.

	Freshwater version	Seawater version
<b>Water motor</b>	Aluminium casting G-AlSi7Mg HC-coated, aluminium bronze, stainless steel V2A, POM, PVDF, NBR, FPM	Bronze casting CuSn10, stainless steel V4A, aluminium bronze, POM, PVDF, NBR, FPM
<b>Prop. pump</b>	Stainless steel V4A, POM, FPM, ceramics, aluminium bronze	Stainless steel V4A, POM, FPM, ceramics, aluminium bronze
<b>Pipework</b>	Stainless steel V2A and V4A, PTFE, FPM, nickel-plated brass	Stainless steel V4A, PTFE, FPM

## ■ 4. FLOW DIAGRAM WITH RETURN LINE CONNECTION.

Proportioning rate 0.5% / 1% / 3% or 6%

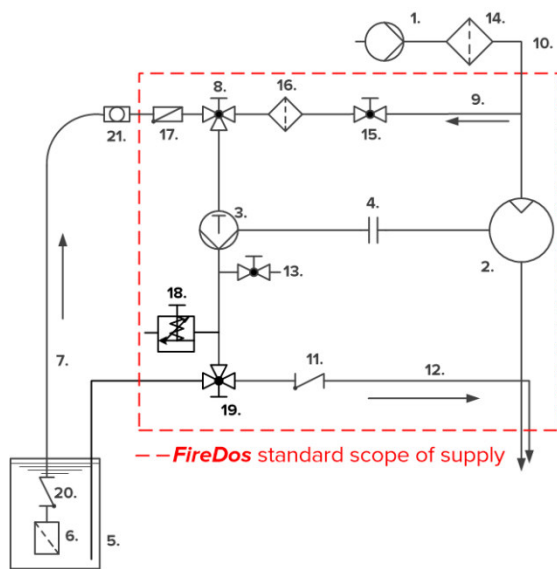

Proportioning rate 3% + 3%

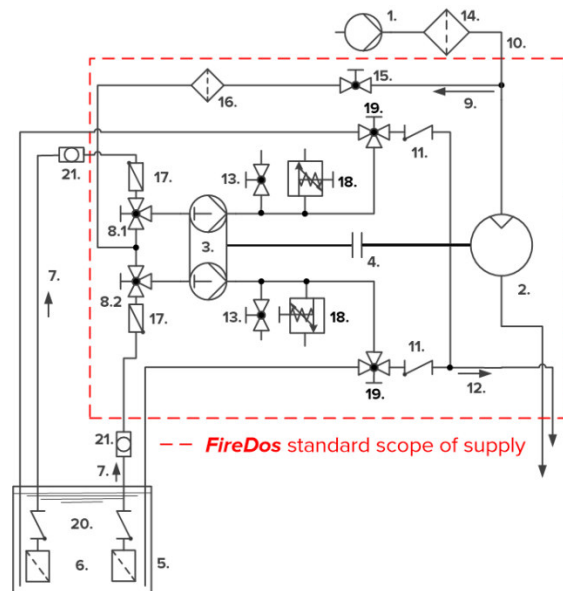

1. Extinguishing water supply
2. Water motor
3. Proportioning pump
4. Coupling
5. Foam agent supply
6. Foot filter
7. Suction line
8. 3-way ball valve "Flushing/Priming"
- 8.1 "Flushing/Priming" pump head I
- 8.2 "Flushing/Priming" pump head II
9. Flushing line
10. Extinguishing water line

11. Check valve in the proportioning line
12. Pressure/proportioning line
13. Air bleed valve
14. Filter in the extinguishing water line
15. Gate valve in the flushing line
16. Filter in the flushing line
17. Non-return flap in the suction line
18. Pressure-relief valve
19. 3-way ball valve "Admixing/Returning"
20. Foot valve\*
21. Ventilation/Filling of the suction line\*

\*) Necessary only with a non-constant course of the suction line

## 5. EXAMPLE FIGURE / DIMENSIONS.

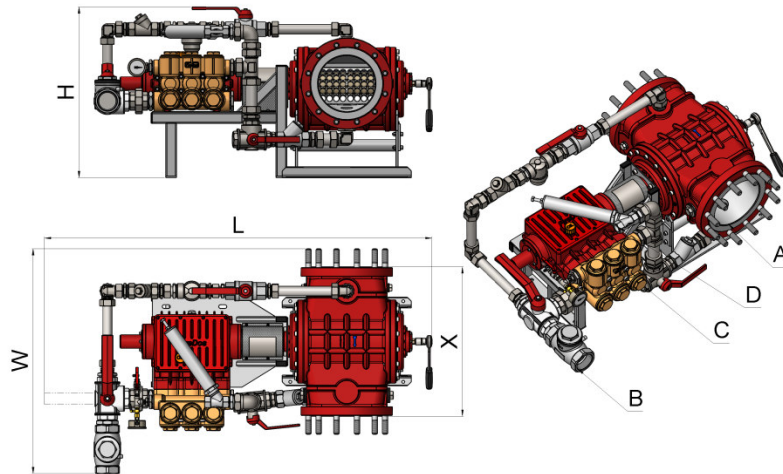

Proportioning rate	0.5%	1%	3%	6%	3% + 3%
Connection water motor A	Optionally: Flange acc. to DIN 2633, DN200 PN16 Flange acc. to ANSI B16.5, 8"-150 lbs/in <sup>2</sup> Flange acc. to JIS B2220 20K-200				
Connection suction line B <sup>6</sup>					
Pump generation I	-	1½" FT BSP	2½" FT BSP	-	-
Pump generation II	¼" FT BSP	½" FT BSP	2½" FT BSP	Flange DN80	2x 2½" FT BSP
Connection return line C	1" FT BSP	1" FT BSP	1½" FT BSP	2" FT BSP	2x 1½" FT BSP
Connection pressure-relief valve D	¾" FT BSP	¾" FT BSP	1" FT BSP	Flange DN50	2x 1" FT BSP
Length L <sup>7</sup>	1245 mm	1270 mm	1451 mm	1923 mm	1558 mm
Height H <sup>7</sup>	520 mm	520 mm	581 mm	1010 mm	752 mm
Width W <sup>7</sup>	690 mm	732 mm	639 mm	1000 mm	960 mm
Installation length in the pipework X	556 mm				

All figures are approximate only and depend on the particular version/equipment options.

6) We will be pleased to advise you on which pump generation to use for your purpose.

7) Further accessories to the proportioner may require more installation space.

Please allow sufficient accessibility of the proportioner for maintenance work.

## 6. MANUFACTURER.

**FireDos** GmbH, Auf der Kaulbahn 6, 61200 Wölfersheim, Germany  
 Phone +49 (0) 6036 9796-0, Email: info@firedos.de

We reserve the right to make modifications at any time.