

■ DATA SHEET PROPORTIONER FD15000 FOR STATIONARY EXTINGUISHING SYSTEMS.

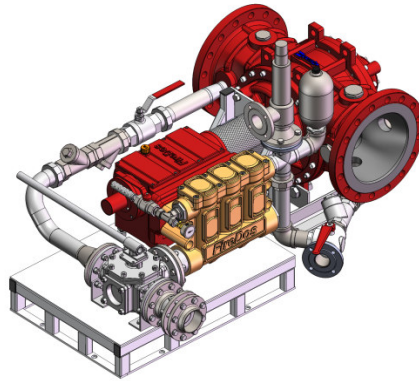

■ 1. TECHNICAL DATA.

Proportioning rate	0.5%	1%	3%	3% + 3%
Approvals	-	FM 3039305 ¹		-
	DNV-GL TAF00000GK ¹			
Flow directions of water motor	Horizontal: "left → right" or "right → left" Vertical: "top → bottom" or "bottom → top"			
Min. water flow rate ²	650 l/min	650 l/min	1100 l/min	1500 l/min
Min. water flow rate ² with flow reduction	220 l/min	220 l/min	370 l/min	500 l/min
Max. water flow rate	15000 l/min			
Operating temperature	5 °C – 50 °C			
Max. operating pressure	16 bar			
Weight ³				
Freshwater version	396 kg	580 kg	883 kg	1400 kg
Seawater version	891 kg	1045 kg	1365 kg	1895 kg
ATEX classification (optional) ⁴	Ex CE II 2G IIC c T4 / II 2D IIIC c T<130°C			

1) Applies to pump generation II.

2) Proportioning starts even at a lower water flow rate. The nominal proportioning rate is achieved when reaching the specified figure.

3) Weight indication is based upon a proportioner with a service crank. Further accessories installed at the proportioner will increase the specified weight. Weight indications do not consider extinguishing water or foam agent.

4) The proportioner does **not** have a service crank if it is an ATEX version. Divergent materials are possible.



2. PRESSURE LOSS.

The actual pressure loss may slightly vary, depending on the operating conditions.

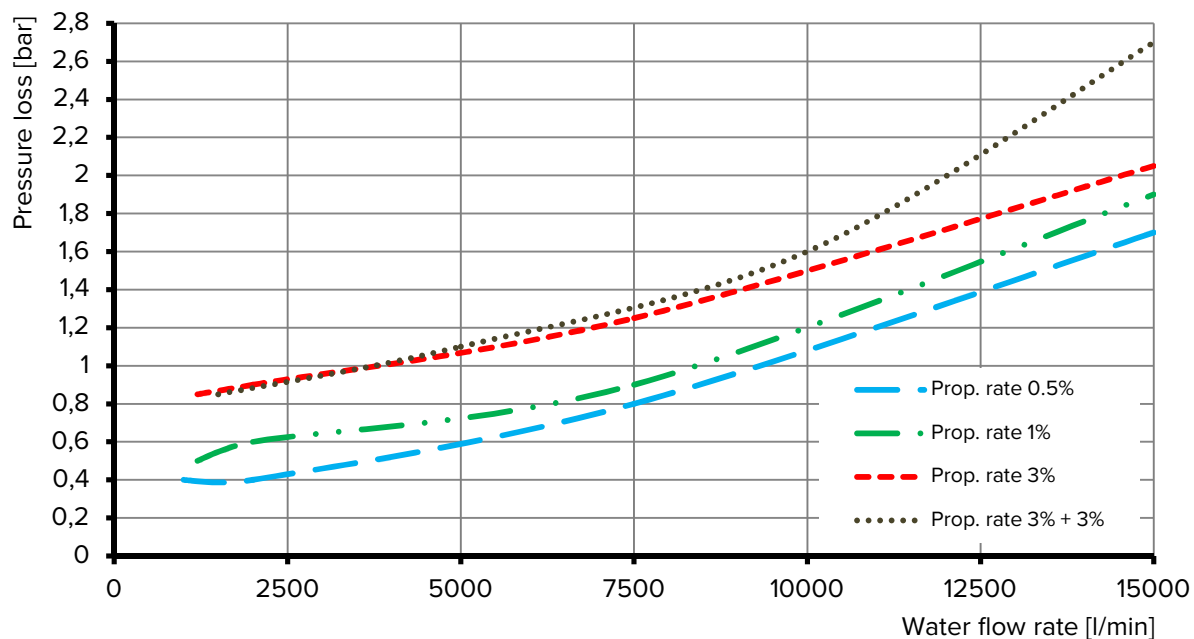

3. MATERIALS.

	Freshwater version	Seawater version
Water motor	Aluminium casting G-AlSi7Mg HC-coated, AlMgSi1 anodised ⁵ , stainless steel V2A, POM, PVDF, NBR, FPM	Bronze casting CuSn10, stainless steel V4A, aluminium bronze, POM, PVDF, NBR, FPM
Prop. pump	Stainless steel V4A, POM, FPM, ceramics, aluminium bronze	Stainless steel V4A, POM, FPM, ceramics, aluminium bronze
Pipework	Stainless steel V2A and V4A, PTFE, FPM, nickel-plated brass	Stainless steel V4A, PTFE, FPM

5) with the 3% + 3% variant: aluminium bronze

■ 4. FLOW DIAGRAM WITH RETURN LINE CONNECTION.

Proportioning rate 0.5% / 1% or 3%

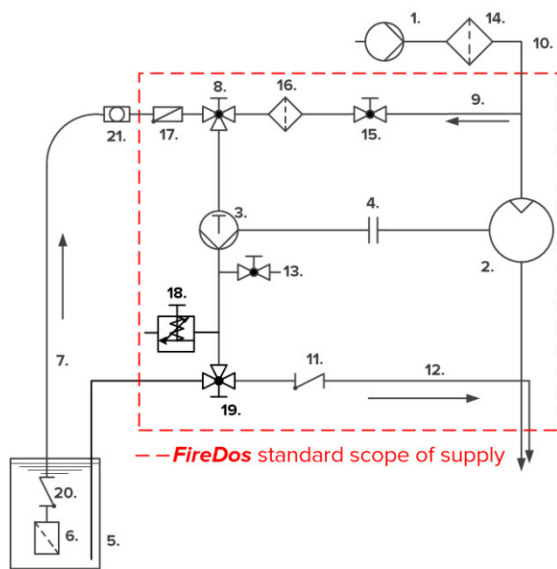

Proportioning rate 3% + 3%

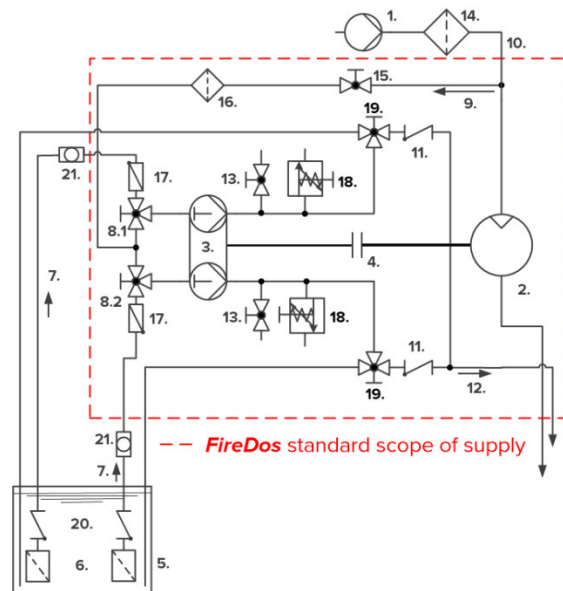

1. Extinguishing water supply
2. Water motor
3. Proportioning pump
4. Coupling
5. Foam agent supply
6. Foot filter
7. Suction line
8. 3-way ball valve "Flushing/Priming"
- 8.1 "Flushing/Priming" pump head I
- 8.2 "Flushing/Priming" pump head II
9. Flushing line
10. Extinguishing water line

11. Check valve in the proportioning line
12. Pressure/proportioning line
13. Air bleed valve
14. Filter in the extinguishing water line
15. Gate valve in the flushing line
16. Filter in the flushing line
17. Non-return flap in the suction line
18. Pressure-relief valve
19. 3-way ball valve "Admixing/Returning"
20. Foot valve*
21. Ventilation/Filling of the suction line*

*) Necessary only with a non-constant course of the suction line

■ 5. EXAMPLE FIGURE / DIMENSIONS.

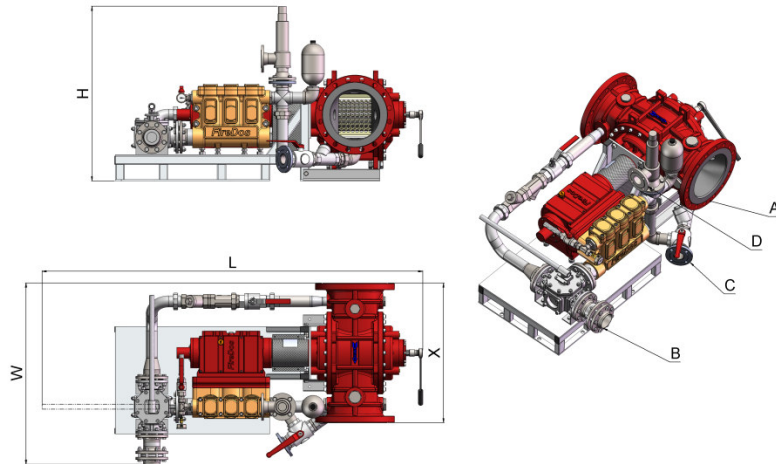

Proportioning rate	0.5%	1%	3%	3% + 3%
Connection water motor A	Optionally: Flange acc. to DIN 2633, DN350 PN16 Flange acc. to ANSI B16.5, 14"-150 lbs/in ² Flange acc. to JIS B2220 20K-350			
Connection suction line B ⁶				
Pump generation I	-	-	-	-
Pump generation II	2" FT BSP	2½" FT BSP	Flange DN100	2x Flange DN100
Connection return line C	1" FT BSP	2" FT BSP	Flange DN65	2x Flange DN65
Connection pressure-relief valve D	¾" FT BSP	1" FT BSP	Flange DN65	2x Flange DN65
Length L ⁷	1704 mm	2004 mm	2854 mm	2689 mm
Height H ⁷	750 mm	806 mm	1211 mm	1271 mm
Width W ⁷	950 mm	1116 mm	1597 mm	1932 mm
Installation length in the pipework X	950 mm			

All figures are approximate only and depend on the particular version/equipment options.

6) We will be pleased to advise you on which pump generation to use for your purpose.

7) Further accessories to the proportioner may require more installation space.

Please allow sufficient accessibility of the proportioner for maintenance work.

■ 6. MANUFACTURER.

FireDos GmbH, Auf der Kaulbahn 6, 61200 Wölfersheim, Germany
Phone +49 (0) 6036 9796-0, Email: info@firedos.de

We reserve the right to make modifications at any time.